

STANDARD PRESSURE TRANSDUCERS DS3/25 PAR

COMPETENCE IN MEASUREMENT ENGINEERING



PAULWEGENER
MESSTECHNIK SEIT 1921

TECHNICAL DATA SHEET PRESSURE TRANSDUCERS

Standard transducers type DS3/25 PAR

The pressure transducer PWB-DS 3/25 PAR is designed for connection to the performance data acquisition system PWBlogg. Equipped with an integrated 16 bit analogue digital converter, the pressure transducer PWB-DS 3/25 provides a high-precision digital measurement signal.

The piezoresistive pressure transducer distinguishes itself by minimal temperature variation, high corrosion resistance and extraordinary robustness against electromagnetic fields. This transducer is available for relative pressure effective ranges of 0...1 bar up to 0...1000 bar.

Technical specifications

Body material	rustproof steel
Body protection degree	IP65 subject to DIN EN 60529
Auxiliary energy	3,5...12 VDC
Output signal	RS485
Compensated temperature range	-10 °C...80 °C
Storage temperature range	-40 °C...120 °C
Process fitting	G 1/2 A (further ones on request)
Medium touching materials	rust-free steel AISI 316L / viton

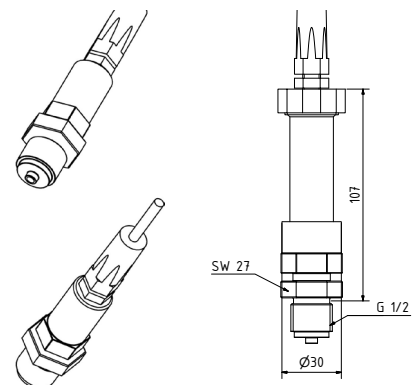

	available	maximum	available	
	measurement ranges	overload	measurement accuracy	
0...	1 bar	2 bar	0,1 %	0,05 %
0...	3 bar	5 bar	0,1 %	0,05 %
0...	10 bar	20 bar	0,1 %	0,05 %
0...	30 bar	60 bar	0,1 %	0,05 %
0...	100 bar	200 bar	0,1 %	0,05 %
0...	300 bar	400 bar	0,1 %	0,05 %
0...	1000 bar	1000 bar	0,1 %	0,05 %



Händlerstempel



PAULWEGENER
MESSTECHNIK SEIT 1921

Adresse | Paul Wegener GmbH | Marienstraße 24 | 06493 Ballenstedt
 Telefon | +49 39483 96-300
 Fax | +49 39483 96-400
 Internet | www.paul-wegener.de
 E-Mail | info@paul-wegener.de